



## MPR PHARMACEUTICAL REFRIGERATORS

### Models:

MPR-N250FH-PE | MPR-N450FH(D)-PE |  
MPR-715F-PE  
MPR-722(R)-PE | MPR-1412(R)-PE  
MPR-S150H-PE | MPR-S300H-PE  
MPR-S500(R)H-PE | MPR-1014(R)-PE

Uniform storage temperature for the most demanding applications. MPR Pharmaceutical Refrigerators offer a complete solution for the most demanding requirements for storage of pharmaceuticals, medicines, vaccines, and other temperature-sensitive applications.



The complete line of PHC Europe B.V. products includes an array of laboratory equipment with the most advanced technology, controls, construction and performance attributes in the industry. Today we apply the most sophisticated refrigeration compressor design and state-of-the-art electronics to ultra-low and cryogenic freezers marketed to life science, pharmaceutical, biotechnology, healthcare and industrial laboratory markets.

PHCbi core technologies, patents, and intellectual properties are represented in every product line. Core technologies apply to critical components and processes such as compressors, microprocessor electronics, and patented VIP vacuum insulation panels. These are engineered to exact specifications for important applications in life science, pharmaceutical, biotechnology, clinical, and industrial laboratories. As a result, PHCbi products operate with dependability, safety, energy efficiency, and ergonomic sensitivity.

# Your innovative partner in **PHARMACEUTICAL REFRIGERATION** solutions

## Table of contents



Commitment to quality	4
Pharmaceutical refrigeration solutions	6
<b>MPR Pharmaceutical Refrigerators with freezer</b>	<b>8</b>
<b>MPR Pharmaceutical Refrigerators</b>	<b>12</b>
<b>MPR Sliding Door Pharmaceutical Refrigerators</b>	<b>15</b>
<b>MPR Refrigerator Dimensions</b>	<b>18</b>

## Committed to Quality

We at PHC Europe B.V. are committed to providing our customers with first class biomedical and pharmacy automation products and supporting services. Our goal is to maintain our market-leading reputation for excellent standards and for consistently living up to our customers' expectations.

Therefore, we are very proud to that PHC Europe B.V.'s quality management system is certified (by TÜV Nederland) to **ISO9001:2015**

We hold the certification that covers the sales, distribution, service and validation of biomedical and pharmacy-automation equipment covering our sites in Etten-Leur (Netherlands), Avon (France) and Loughborough (UK).



**Life Science  
Innovator  
Since 1966**

Quality - It's a word that all are familiar with and one which many manufacturers claim to have or strive for. In the view of PHC, quality is a term that is ultimately defined by the customer. When quality becomes a customer-driven concept, quality includes meeting or exceeding our customers' needs or expectations. We focus on total quality which includes advanced processes and the culture of our organization. The result of our total quality initiatives involve many steps to provide our customers with superior value.

### 10 steps to guarantee superior value

#### Understanding Customer Demands

Our vision of total quality involves many face-to-face visits to customers to directly hear what they have to say about using the equipment we have supplied.

#### Creating a New Product Concept

Developing a concept for a new product is very similar to the "basic research" processes in life sciences. Technical staff and engineers develop various basic and innovative technologies to realize the concept for a new product.

#### Creating a New Product Designs

As soon as engineering personnel begin developing a technological element, the design staff sets out to work on images.

#### Checking Local Legislation

We manufacture products for use in approximately 110 countries and regions around the world. Obviously, different laws and regulations apply, so we are always working to ensure our products conform to the laws and regulations of the individual locations

#### Design Review

Beyond determining specifications, evaluation criteria and achievement levels affecting product quality such as reliability, durability and safety standards must be achieved in mass-production models.

Founded in 1990 as subsidiary of the PHC Holdings Corporation, it is our mission to become a leading, trusted brand for sustainable healthcare and biomedical product solutions, which support the work of our customers to improve the health and well-being of people around the world.

For more than 25 years now, we respond to the needs of our pharmaceutical, biotechnology, hospital/clinical and industrial customers, offering an unique perspective on scientific research in general. As a result we play a critical role in product development for worldwide applications and have established a reputation as a manufacturer of high-quality and innovative medical and laboratory equipment.

Long lasting relationships have been built with leading pharmaceutical, healthcare and biotechnology companies as well as with major academic and research institutes in Europe. PHC Europe B.V. has set

the standard in many aspects. V.I.P. panels, Cool Safe compressors, Active Background Contamination Control and the world's first -152 °C ULT freezer. Where PHC Europe B.V. took the initiative, the others followed. This made us a very important player in both the ultra-low temperature and the CO<sub>2</sub> market.

PHC Europe BV, part of the PHC Corporation, Biomedical Division, manages sales, marketing, logistics and technical service of PHCbi laboratory products throughout Europe (including Russia and Turkey). Headquartered in the Netherlands with sales and service organizations in the UK, France and the Netherlands.

In the Dutch warehouse, about 1.000 units are waiting to be delivered directly from stock. Within a couple of days, spare parts can be delivered in every part of Europe. That's one of the strengths of PHC's European sales organization.



### Quality Assurance

Under PHC standards, quality actions required in new product development must clear three hurdles: AQ-0 approval for design completion, AQ-1 decision for shifting to mass production and AQ-2 decision for shipping mass-produced units.

### Mass Production

The Gunma factory was established in 1959 as the Tokyo manufacturing site for Sanyo Electric Co., Ltd. It is a core facility housing the Product Technology Development & Design Department, Quality Assurance Department and Production Department.

### Transportation packaging design

Our product packaging is designed to fulfill various distribution challenges around the world. Using past accumulated lessons learned we focus on reducing and recycling materials to support environmental initiatives.

### Installation

Product installations are often performed carefully by regional suppliers who are trained specialists. The path from facility entrance to the laboratory is measured and examined in advance to ensure precise, efficient installation. In some regions 'white glove' service is also available to aid in installation and set-up.

### Sales and After-Sales Service

We always strive to learn more about our products. Before new products go into mass production at the factory, our sales personnel receives extensive knowledge about the products through intensive sales training

# MPR Pharmaceutical Refrigerators

MPR Pharmaceutical Refrigerators are specially designed to comply with pharmaceutical regulations. Exceptional temperature uniformity is paired with easy calibration access to meet critical validated storage regulations. A thermistor sensor monitors temperature inside the chamber, while microprocessor controls ensure that an accurate set temperature is maintained. Even with frequent door openings, the circulation fan provides rapid temperature recovery for a stable preservation environment unaffected by ambient temperature.

The MPR Pharmaceutical Refrigerators are not only complete and integrated solutions for pharmaceuticals, medicines and temperature sensitive biologicals, but also suitable for the stable and reliable laboratory requirements. The refrigerators provide an ideal temperature environment for clinical, pharmaceutical and industrial research. At PHCBI we believe that there has to be a specific refrigerator for your requirements. So we offer also sliding door refrigerators and refrigerator/freezer combination to accommodate your wishes.



## ADVANCED MONITORING AND SAFETY FEATURES

Minimise the risks to important biological samples and experiments with added sample security. Comprehensive set point, alarm monitoring, and diagnostic functions are supervised by the PHCBI-built, microprocessor controller, with digital display of all input/output function. Visual and audible signals alert users to any abnormal conditions enabling them to take prompt action, while a potential remote alarm contact ensures added peace of mind even during non-working hours.

## QUIET OPERATION

The specially-designed compressors offer quiet operation for installation in busy working environments without disruption.

## PLENUMS DIRECT AIRFLOW

PHCBI's Plenum design features uniform cold air flow distribution throughout the chamber to ensure temperature uniformity – essential for validated storage requirements.

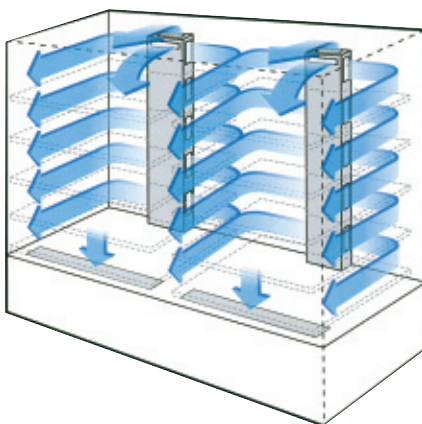

## UNIFORM TEMPERATURES

Temperature uniformity throughout the refrigerator ensures that all samples can be stored in identical conditions. PHCBI's Forced Air Circulation technology quickly restores temperature uniformity following routine door openings. Coupled with fast-response microprocessor temperature control ensures a stable environment for biological samples.

## CYCLE DEFROST FUNCTION FOR STABLE TEMPERATURES

PHCBI's Cycle Defrost system design ensures that defrost occurs only when necessary and is not based on time. This system runs automatically by constantly monitoring refrigeration temperature increase during defrost, ensuring that this is minimal with no temperature spikes. The evaporation heater also adds additional protection against excessive decrease in cabinet temperature, which can be caused by low ambient temperature.

## COMPARISON WITH DOMESTIC REFRIGERATORS

PRODUCT CHARACTERISTICS	MPR SERIES	DOMESTIC REFRIGERATOR
CFC-FREE, RELIABLE TEMPERATURE CONTROL NOT AFFECTED	✓	⊗
DIGITAL DISPLAY OF CHAMBER TEMPERATURE	✓	⊗
PRECISE TEMPERATURE SETTING OF CHAMBER WITH MICROPROCESSOR CONTROL	✓	⊗
DIGITAL VARIABLE TEMPERATURE CONTROL OF REFRIGERATOR (2 °C TO 14 °C)	✓	⊗
VARIABLE TEMPERATURE CONTROL OF FREEZER (-20 °C TO -30 °C)	✓	Max/Mid/Min
UNIFORM TEMPERATURE AT ALL SHELF LEVELS	✓	⊗
SEPARATE OPERATION OF REFRIGERATOR AND FREEZER**	✓	⊗
WINDOW FOR VIEWING	✓	⊗
OPTIMIZED SPACE DEDICATED TO STORAGE	✓	⊗
ACCESS PORT FOR REMOTE MONITORING	✓	Some Models Yes
DIGITAL OR CIRCULAR TEMPERATURE RECORDER (OPTIONAL)	✓	⊗
DOOR AJAR TRIGGERS INDICATOR LIGHT AND AUDIBLE ALARM	✓	Some Models Yes
IRREGULAR TEMPERATURE TRIGGERS ALARM (OPTIONAL)	✓	⊗
REMOTE ALARM TERMINAL (OPTIONAL ON SOME MODELS)	✓	⊗
SET TEMPERATURE DEVIATION	✓	⊗
SELF DIAGNOSTIC FUNCTION	✓	⊗
UNIQUE CYCLE DEFROST / AUTOMATIC DEFROST SYSTEM	✓	⊗
CONDENSATE EVAPORATOR	✓	✓
OPTIONAL APP BASED WIRELESS MONITORING	✓	⊗

# MPR Pharmaceutical Refrigerator with Freezer

Providing a complete storage solution; refrigerator and freezer in one unit PHCBI's pharmaceutical refrigerators with freezer combine high-performance refrigeration with a -30 °C freezing environment within a small footprint for flexible, reliable and convenient sample storage. Natural refrigerants minimize environmental impact for a sustainable storage solution.

## Natural Refrigerants



Naturally occurring hydrocarbon (HC) refrigerants have minimal effect on the environment and are compliant with environmental legislation for climate control.

## Inverter Compressors



The intelligent control of the inverter compressor optimizes running speed. When the inverter compressor is running as normal it will stay on for longer than a conventional compressor but at a minimal speed. This reduces the power consumption and keeps freezer temperatures stable.

## ENVIRONMENTALLY FRIENDLY STORAGE SOLUTION

Naturally occurring hydrocarbon (HC) refrigerants have minimal effect on the environment and are compliant with environmental legislation for climate control. Combined with inverter technology, these refrigerants also provide more efficient cooling and lower running costs.

Ideal for laboratories looking to reduce their carbon footprint and environmental impact to comply with sustainability policies.



Model: MPR-N450FH-PE

Model: MPR-N250FH-PE



## STABLE, UNIFORM TEMPERATURES

Inverter compressor (refrigerator compartment) can run at a range of speeds depending on the cooling requirement, ensuring a stable temperature. A duct system ensures uniform temperature distribution throughout the refrigerator and fast recovery of temperature after routine door openings to minimise fluctuation.

The MPR-N450FHD-PE is specifically designed for high performance sample storage. The refrigerator compartment is suitable for drug storage in accordance with the DIN 58345 standard.

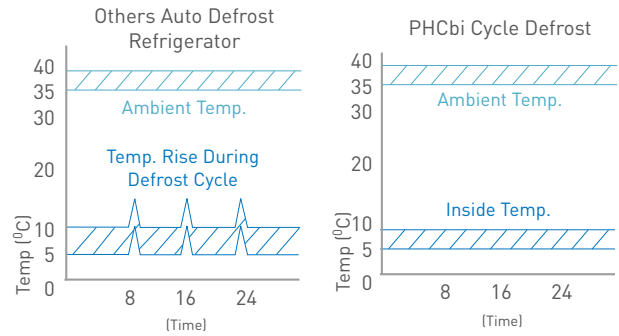

Cycle Defrost Function Data

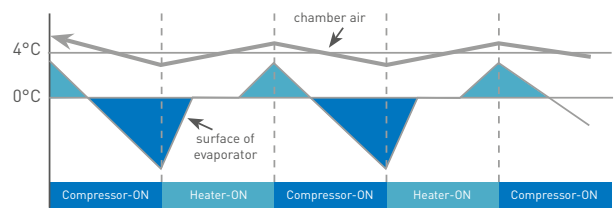

**Microprocessor controls:**

- Microprocessor controller.
- Calibration adjustment through the control panel available.
- Integrated alarm functions.

**Cycle defrost:**

- Unique Cycle Defrost (refrigerator only) initiates only as required and maintains internal temperature uniformity, without fluctuation.

**Dual refrigeration systems:**

- Separate refrigeration systems and compressors allow differential control of the individual refrigerator and freezer compartments, allowing the freezer section to maintain temperatures as low as -30 °C.

**Cabinet construction:**

- Double-pane windows with special heat reflection film for added protection against heat and UV.
- Energy-saving LED lighting\*.
- Interior forced air circulation

\* only in MPR-N250FH-PE and MPR-N450FH(D)-PE

## OLED Control Panel



The OLED panel has good visibility and intuitive operation. It displays detailed temperatures with increment of 0.1 °C, alarm conditions and minimal and maximal temperature for every 12/24 hours. The USB port and data log functions simplifies temperature data management.



## PRECISE CONTROL & INTELLIGENT MONITORING

A microprocessor controller and accurate sensors maintain precise refrigerator and freezer temperatures that are displayed simultaneously on an OLED panel. A USB port provides simple and convenient transfer of logged data to a PC including temperature, door opening times and alarm history. The OLED panel has good visibility and intuitive operation. It displays detailed temperatures with increment of 0.1 °C, minimal and maximal temperature for every 24 hours and can show refrigerator and freezer temperature simultaneously. The USB port and log functions simplifies temperature data management.

## LED INTERIOR LIGHT

The LED interior light automatically turns on/off in combination with the door opening/closing. It can also be controlled from the control panel.



## SUPERIOR UNIFORMITY

The refrigerator provides superior uniformity throughout. Temperatures remain stable wherever products are stored, even in a fully loaded chamber. The refrigerator is engineered to prevent inadvertent freezing of temperature sensitive vaccines.

The refrigerator includes a high performance refrigeration system with a forced air, back wall plenum. This provides even, horizontal airflow across the solid, adjustable glass shelves at each shelf level. A uniform freezer temperature is maintained through a cold wall refrigeration system with natural circulation.



## OPTIONAL CONTAINERS

Optional containers for the freezer compartment are available for flexible storage solutions.





Pharmaceutical Refrigerators with Freezer					
Model Number		MPR-N250FH-PE	MPR-N450FH-PE	MPR-N450FHD-PE <sup>1)</sup>	MPR-715F-PE
Temperature control range	°C	+2 to +14 (Ref), -35 to -15 (Frz)*		+5 (Ref), -35 to -15 (Frz)*	+2 to +14 (Ref), -35 to -15 (Frz)*
External dimensions (WxDxH)	mm	510 x 640 x 1810	800 x 640 x 1810	800 x 640 x 1810	900 x 715 x 1910
Internal dimensions (WxDxH)	mm	430 x 516 x 903 (Ref)	720 x 516 x 913 (Ref)	720 x 516 x 913 (Ref)	810 x 615 x 1894 (Ref)
		390 x 501 x 413 (Frz)	680 x 470 x 415 (Frz)	680 x 470 x 415 (Frz)	770 x 552 x 422 (Frz)
Volume	litres	179/80 (Ref/Frz)	326/136 (Ref/Frz)	326/136 (Ref/Frz)	415/176 (Ref/Frz)

\* Complies with Art. 11, Annex III of F-Gas Regulation (EU) No 517/2014. Contains fluorinated greenhouse gases in hermetically sealed equipment.

<sup>1)</sup> The MPR-N450FHD-PE is specifically designed for high performance sample storage. The refrigerator compartment is suitable for drug storage in accordance with the DIN 58345 standard.

## Optional accessories

### OPTIONS

Pharmaceutical Refrigerators with Freezer			
Model Number	MPR-N250FH-PE	MPR-N450FH-PE / MPR-N450FHD-PE	MPR-715F-PE
Temperature recorders			
Temperature chart recorder	MTR-0621LH-PE (Ref)	MTR-0621LH-PE	-
- chart paper	RP-06-PW	RP-06-PW	-
- recorder housing	MPR-S30-PW	MPR-S30-PW	-
Circular type	MTR-G3504C-PE (Ref/Frz)	MTR-G3504C-PE	MTR-G3504C-PE
- chart paper	RP-G3504-PW	RP-G3504-PW	RP-G3504-PW
- Ink pen	PG-RB-PW	PG-RB-PW	PG-RB-PW
- recorder housing	MPR-S7-PW		
Continuous strip type	MTR-4015LH-PE (Frz)	MTR-4015LH-PE	MTR-0621LH-PE (Ref) / MTR-4015LH-PE (Frz)
- chart paper	RP-40-PW	RP-40-PW	RP-06-PW (Ref) / RP-40-PW (Frz)
- recorder housing	MPR-S30-PW	MPR-S30-PW	MPR-S30-PW
Battery kit for power failure alarm	MPR-48B2-PW	MPR-48B2-PW <sup>1)</sup>	
Wired Shelf for freezer (set of two)	MPR-250ST-PW		
Containers inside freezer	MPR-25BP-PW	MPR-45FSC-PW	MPR-715SC-PW
Door window blanking plates		MPR-45BP-PW	

<sup>1)</sup> Supplied as standard on MPR-N450FHD-PE

# MPR Pharmaceutical Refrigerators

Stable and reliable for exacting laboratory requirements. Ideal temperature environment for clinical research, pharmaceutical and industrial use. Adjustable shelves and wide range set point for varying laboratory applications including chromatography and pharmaceutical storage. With a temperature range of 2 °C to 23 °C, PHCbi Pharmacy Refrigerator are ideally suited for many tests that require a stable, cool temperature or general cold storage. A filterless condenser cuts down on cleaning maintenance. Also, all glass doors now include a protective film to prevent shattering.

## WIDE TEMPERATURE RANGE

The temperature of the MPR-722(R) and MPR-1412(R) can be set between 2 °C and 23 °C. MPR Pharmaceutical Refrigerators offer a complete solution for the most demanding requirements for storage of pharmaceuticals, medicines, vaccines, and other temperature-sensitive applications.

## SOLID CABINET CONSTRUCTION:

The broad, solid frames with effective gaskets ensure excellent temperature stability, whilst double-pane glass windows offer an excellent view of the interior. Optional panels are available to block out light.

## USER-FRIENDLY DESIGN

The broad, solid frames with effective gaskets ensure excellent temperature stability, whilst double-pane glass windows offer an excellent view of the interior. Optional panels are available to block out light.

## EXCELLENT STABILITY

The quiet, 120mm diameter fan ensures an even temperature throughout the cabinet. (MPR-1411-PE models have a double-flow system with two fans), creating tight  $\pm 3$  °C uniformity, whilst maintaining excellent recovery characteristics.



Model: MPR-1412-PE

Model: MPR-722-PE



## DRAWER TYPE SHELVES

The 'R' models are fitted with pull-out drawers, with dimensions of 530 mm x 550 mm and a 100 mm front profile, ideal for holding large bottles and reagent kits. They also allow convenient, space efficient storage and management of samples.



## ADJUSTABLE SHELVES

565 mm x 604 mm shelves are strong enough to withstand a load of up to 50 kg in the MPR-722 while shelves in the MPR-1412 can hold up to 40 kg with ease. The shelves can be arranged to accommodate tall apparatus, such as chromatography equipment. Heavier equipment can be accommodated with the Heavy Load Shelves.



## HEAVY LOAD SHELVES FOR CHROMATOGRAPHY APPLICATIONS

The pull-out Stainless Steel shelves were designed for the MPR-722-PE and the MPR-1412-PE in combination with the use of a HPLC/ Chromatography unit. The special heavy-duty shelves ensure a safe work environment and can withstand a load of 100 kg. Upon customer request the heavy load shelf can be fixed on different heights. The MPR should be fixed to the wall to ensure that it will not fall forwards when pulling out the shelf.

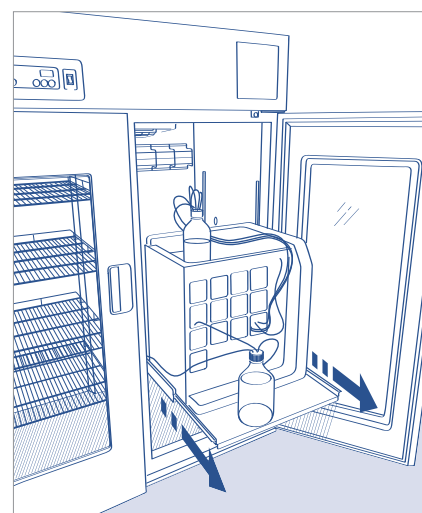

## Alarms & Safety Features

FEATURE	TRIGGER	TYPE OF ALARM/RESPONSE
HIGH TEMPERATURE ALARM	2 °C to 14 °C (selectable) above setpoint	Flashing LED & audible alarm after 15 minutes
LOW TEMPERATURE ALARM	2 °C to 14 °C (selectable) below setpoint & 0 °C or lower	Flashing LED & audible alarm
TEMPERATURE LOCK	Lock ON	Set temperature and alarm points cannot be altered
MEMORY BACKUP	Power failure	Memory of settings
DOOR AJAR	Door not closed	Door ajar lamp ON, adjustable audible alarm from 1 to 15 minutes
SELF DIAGNOSTICS	Sensor failure and fan or compressor abnormality	Error code shown
REMOTE ALARM CONTACTS	N.O. and N.C. contact available for hook up to an auxiliary alarm system	Dry Contacts
TEMPERATURE RECORDER	Optional, Model #MTR-C954, 7-day 6" circular chart or touch panel digital temperature recorder	N/A

## EASY ACCESS FRONT CONTROL PANEL

A large LED display of actual temperature with intuitive touch pad setting makes operation simple. It displays detailed temperatures with increment of 0.1 °C



MPR Pharmaceutical Refrigerators					
Model Number		MPR-722-PE	MPR-722R-PE	MPR-1412-PE	MPR-1412R-PE
Temperature control range	°C	+2 to +23 °C		+2 to +23 °C	
External dimensions (WxDxH)	mm	770 x 920 x 1955		1440 x 830 x 1950	
Internal dimensions (WxDxH)	mm	650 x 710 x 1500		1320 x 710 x 1500	
Volume	litres	684	671	1364	1359
Type		Wire shelves type	Drawer type	Wire shelves type	Drawer type
Number of shelves/drawers		4 wired shelves	5 coated steel drawers	8 wired shelves	10 coated steel drawers

## Optional accessories

### OPTIONS

MPR Pharmaceutical Refrigerators		
Model Number	MPR-722-PE / MPR-722R-PE	MPR-1412-PE / MPR-1412R-PE
Temperature recorders		
Temperature chart recorder	MTR-0621LH-PE	MTR-0621LH-PE
- chart paper	RP-06-PW	RP-06-PW
- recorder housing	MPR-S30-PW	MPR-S30-PW
Circular type	MTR-G04C-PE	MTR-G04C-PE
- chart paper	RP-G04-PW	RP-G04-PW
- Ink pen	PG-R-PW	PG-R-PW
- recorder housing	MPR-S7-PW	MPR-S7-PW
External mounting power failure alarm	MPR-48B-PW (V-B)	MPR-48B-PW (V-B)

# MPR Sliding Door Refrigerators

The Pharmaceutical Sliding Door Refrigerators offer a complete solution for the most demanding requirements for storage of pharmaceuticals, medicines, vaccines, and other temperature-sensitive applications.

Manufactured and distributed by PHCbi, all our Laboratory Refrigerators / Pharmacy Fridges / Vaccine Fridges / lab fridges are designed to meet the most exacting standards required of a specialist Pharmaceutical Refrigerator. Effective, reliable temperature control, quiet operation, ease of use and ergonomic design are just a few of the features you can expect as standard from a PHCbi Refrigerator.

## Natural Refrigerants



Naturally occurring hydrocarbon (HC) refrigerants improve performance and reduce running costs.

## Inverter Compressors



The intelligent control of the inverter compressor optimizes running speed. When the inverter compressor is running as normal it will stay on for longer than a conventional compressor but at a minimal speed. This reduces the power consumption and keeps freezer temperatures stable.



Model: MPR-S300H-PE

Model: MPR-S150H-PE

## ENVIRONMENTALLY FRIENDLY

Naturally occurring hydrocarbon [HC] refrigerants have minimal effect on the environment and are compliant with environmental legislation for climate control. Combined with inverter technology, these refrigerants also provide more efficient cooling without compromising performance.].

## STABLE TEMPERATURES

Inverter compressors provide optimum stability, while quality of design ensures reliability. Ideal for samples that are sensitive to temperature fluctuations. HC refrigerant consumes about 64% less energy than conventional models.

## PLENUMS DIRECT AIRFLOW:

PHCbi's Plenum design features uniform cold air flow distribution throughout the chamber to ensure temperature uniformity – essential for validated storage requirements.

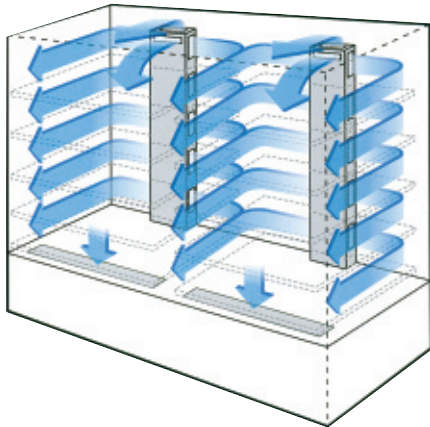

## OLED Control Panel



The OLED panel has good visibility and intuitive operation. It displays detailed temperatures with increment of 0.1 °C, alarm conditions and minimal and maximal temperature for every 12/24 hours. The USB port and data log functions simplifies temperature data management.



Model: MPR-S500RH-PE

### Safe & Secure storage

- Adjustable audible and visual alarms are standard, along with integrated system diagnostics and predictive performance. The password-protected control panel provides security and minimises risk of accidental changes. If desired alarm and operating history can be uploaded through the USB port.

### LED Interior Light

- The LED interior light automatically turns on/off in combination with the door opening/closing. It can also be controlled from the control panel.

### Defrost Methods

- Both models includes automatic defrost which activates electronically when needed. The refrigerator evaporator operates above freezing at all times. This prevents vaccines and lab supplies from freezing..

### User-friendly Design

- The ergonomic design provides a clear view of stored items through the large framed windows. The slim profile allows easy retrieval, and the selfclosing sliding doors makes them ideal for limited spaces.

### Well-insulated chamber

- Double glass separated by an extra wide 12 mm gap contains argon gas to protect samples from exterior heat. Combined with air blowing up from the chamber bottom, the unit completely safeguards samples and maximises energy efficiency.





MPR Pharmaceutical Refrigerators Sliding door type

Model Number	MPR-S150H-PE		MPR-S300H-PE
Temperature control range	°C	+2°C to +14°C	
External dimensions (WxDxH)	mm	800 x 500 x 1120	800 x 500 x 1820
Internal dimensions (WxDxH)	mm	720 x 360 x 725	720 x 360 x 1435
Volume	litres	165	345
Type		Wire shelves type	Wire shelves type

\* Complies with Art. 11, Annex III of F-Gas Regulation (EU) No 517/2014. Contains fluorinated greenhouse gases in hermetically sealed equipment.



MPR Pharmaceutical Refrigerators Sliding door type

Model Number	MPR-S500H-PE	MPR-S500RH-PE	MPR-1014-PE	MPR-1014R-PE
Temperature control range	°C +2°C to +14°C			
External dimensions (WxDxH)	mm 900 x 650 x 1824		mm 1800 x 600 x 1790	
Internal dimensions (WxDxH)	mm 800 x 510 x 1425		mm 1700 x 465 x 1300	
Volume	litres 554	litres 550	litres 1033	litres 1029
Type	Wire shelves type	Drawer type	Wire shelves type	Drawer type

# Optional accessories

## OPTIONS

MPR Pharmaceutical Refrigerators Sliding door type			
Model Number	MPR-S150H-PE / MPR-S300H-PE	MPR-S500H-PE / MPR-S500RH-PE	MPR-1014-PE / MPR-1014R-PE
Temperature recorders			
Temperature chart recorder	MTR-0621LH-PE	MTR-0621LH-PE	MTR-0621LH-PE
- chart paper	RP-06-PW	RP-06-PW	RP-06-PW
- recorder housing	MPR-S30-PW	MPR-S30-PW	MPR-S30-PW
Circular type	MTR-G04C-PE	MTR-G04C-PE	MTR-G04C-PE
- chart paper	RP-G04-PW	RP-G04-PW	RP-G04-PW
- Ink pen	PG-R-PW	PG-R-PW	PG-R-PW
- recorder housing	MPR-S7-PW	MPR-S7-PW	MPR-S7-PW
Battery kit for power failure alarm	MPR-48B2-PW (V-B)	MPR-48B2-PW (V-B)	MPR-48B-PW (V-B)
Door window blanking plates	MPR-S150H-PE: EP-COVER-L* MPR-S300H-PE: EP-COVER-H*		
Drawer Rack	MPR-31RR-PW (for lower right side) MPR-31LR-PW for lower left side (MPR-S300H only)		

\*window cover consists of 1 piece

## OPTIONS

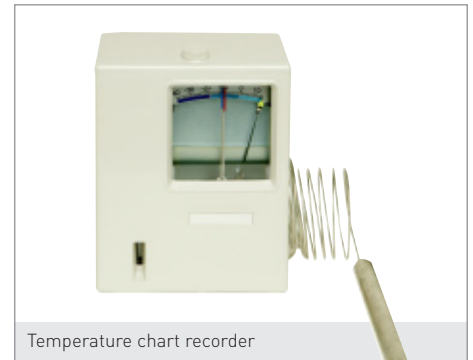

# Dimensions

## MPR Pharmaceutical Refrigerators with Freezer

MPR-N250FH-PE

MPR-N450FH(D)-PE

MPR-715F-PE

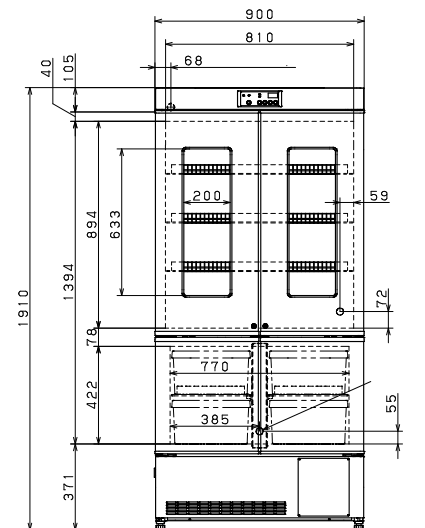
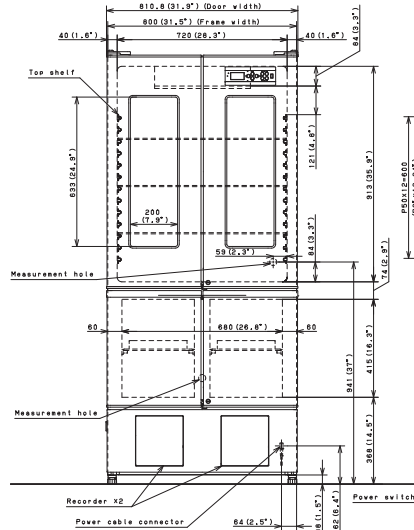
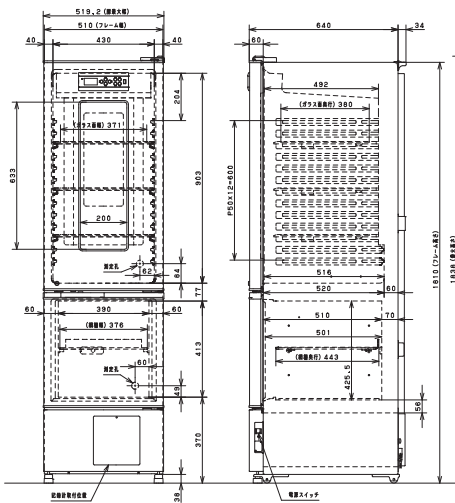

MPR Pharmaceutical Refrigerators

MPR1411-PE / MPR1411R-PE

MPR722-PE / MPR722R-PE

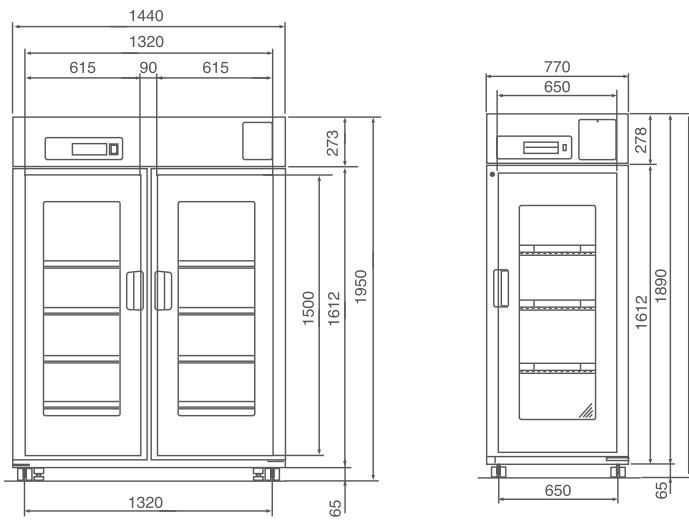

Sliding Door Pharmaceutical Refrigerators

MPR-S150H-PE

MPR-S300H-PE

MPR-S500H-PE

MPR-S500RH-PE

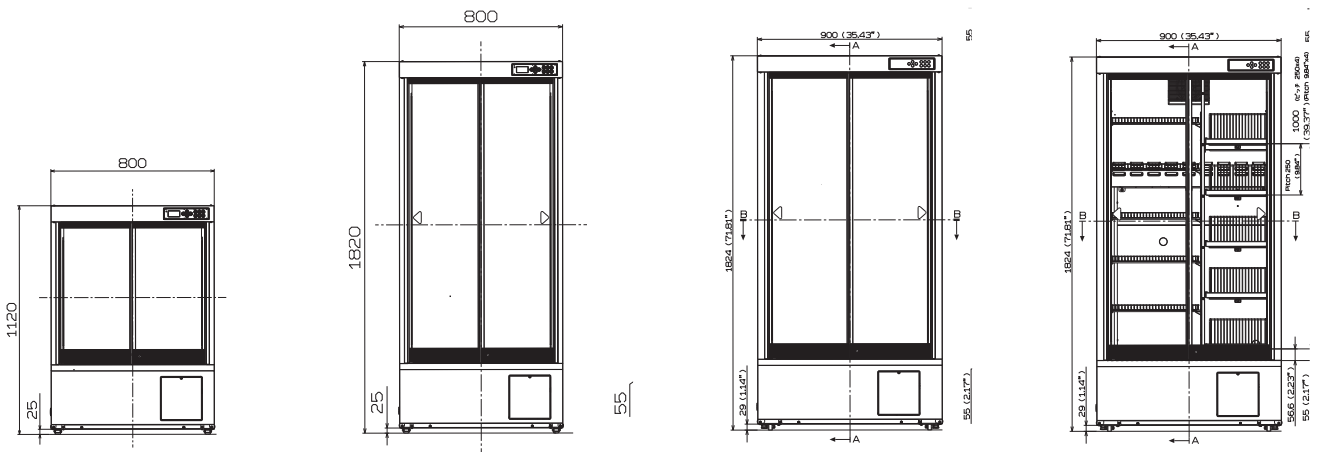

MPR-1014R-PE

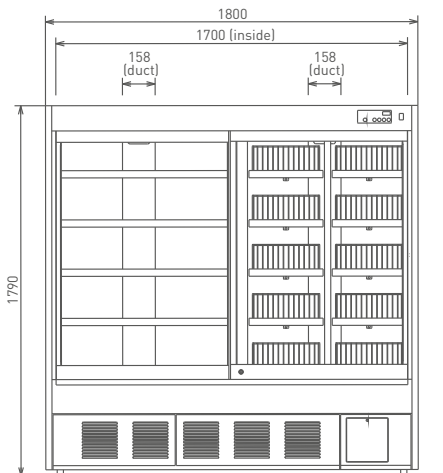



**000 «Диаэм»**

**Москва**  
ул. Магаданская, д. 7, к. 3 ■ тел./факс: (495) 745-0508 ■ [sales@dia-m.ru](mailto:sales@dia-m.ru)

[www.dia-m.ru](http://www.dia-m.ru)

**С.-Петербург**  
+7 (812) 372-6040  
[spb@dia-m.ru](mailto:spb@dia-m.ru)

**Новосибирск**  
+7(383) 328-0048  
[nsk@dia-m.ru](mailto:nsk@dia-m.ru)

**Воронеж**  
+7 (473) 232-4412  
[vrn@dia-m.ru](mailto:vrn@dia-m.ru)

**Йошкар-Ола**  
+7 (927) 880-3676  
[nba@dia-m.ru](mailto:nba@dia-m.ru)

**Красноярск**  
+7(923) 303-0152  
[krsk@dia-m.ru](mailto:krsk@dia-m.ru)

**Казань**  
+7(843) 210-2080  
[kazan@dia-m.ru](mailto:kazan@dia-m.ru)

**Ростов-на-Дону**  
+7 (863) 303-5500  
[rnd@dia-m.ru](mailto:rnd@dia-m.ru)

**Екатеринбург**  
+7 (912) 658-7606  
[ekb@dia-m.ru](mailto:ekb@dia-m.ru)

**Кемерово**  
+7 (923) 158-6753  
[kemerovo@dia-m.ru](mailto:kemerovo@dia-m.ru)

**Армения**  
+7 (094) 01-0173  
[armenia@dia-m.ru](mailto:armenia@dia-m.ru)

