



Safety storage cabinet Q-PEGASUS-90
Model Q90.195.060.WDAC, body colour anthracite grey
(RAL 7016), with wing door in warning yellow (RAL 1004)

Safe and approved storage of flammable hazardous substances in working areas

Function / construction:

- **Robust construction and longevity:** triple hinged door, safety elements assembled outside the storage compartment for increased protection against corrosion, scratch- and impact-resistant surface, easy to clean
- **User-friendly and safe:** door open arrest system (standard), convenient and safe removal or storage of containers
- **Always closed:** serial automatic door closing (TSA) releases arrested door after approx. 60 seconds; acoustic and visual signal before closing
- **No unauthorised use:** door lockable with cylinder locking (integration in an existing locking system possible) and locking state indicator (red/green)
- **Easy transport:** integrated transport base with removable, optional base cover
- **Easy alignment:** adjusting aids to compensate for uneven floor
- **Ventilation:** integrated air ducts ready for connection (DN 75) to a technical exhaust system, spinning wheel in the exhaust grid as an indicator of sufficient technical ventilation

Dimensions

Width (external)	599 mm
Depth (external)	615 mm
Height (external)	1953 mm
Width (internal)	450 mm
Depth (internal)	522 mm
Height (internal)	1647 mm

The available internal dimensions can vary depending on the interior equipment package.

Weight / Load

Weight without interior equipment	265 kg
Distributed load	894 kg/m ²
Maximum load	600 kg

Ventilation

Extraction air	75 DN
minimum exhaust air quantity 10 times	4 m ³ /h
Pressure drop inside the cabinet	5 Pa

Colouring / Surface finish

Body colour code	RAL 7016
Body colour	anthracite grey
Body surface finish	textured
Door / Drawer colour code	RAL 1004
Door / Drawer colour	Warning yellow
Door / Drawer surface finish	textured

General Information

Number of doors	1
Door opening angle	89.00°
Depth with open doors	1128 mm
Interior grid dimension	32 mm
Entry width transport base	526 mm
Entry height transport base	90 mm
Customs tariff number	94032080



Front view

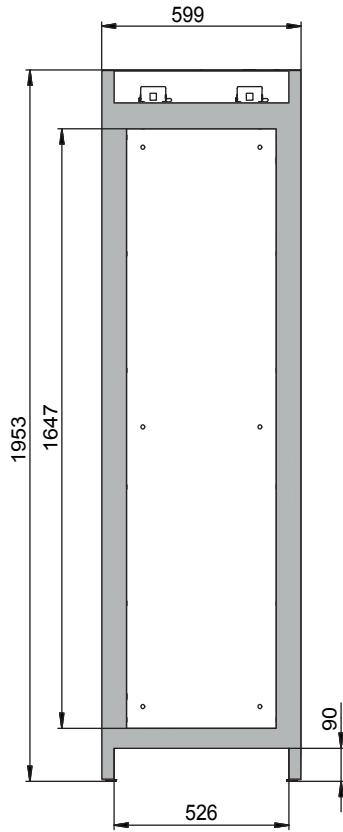

Side view

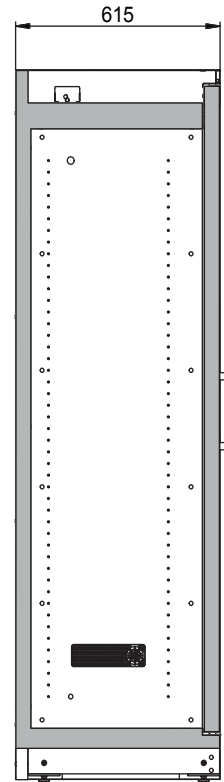

Top view

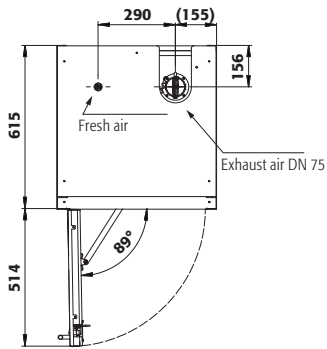

000 «Диаэм»

Москва
ул. Магаданская, д. 7, к. 3 ■ тел./факс: (495) 745-0508 ■ sales@dia-m.ru

www.dia-m.ru

С.-Петербург
+7 (812) 372-6040
spb@dia-m.ru

Новосибирск
+7 (383) 328-0048
nsk@dia-m.ru

Воронеж
+7 (473) 232-4412
vrn@dia-m.ru

Йошкар-Ола
+7 (927) 880-3676
nba@dia-m.ru

Красноярск
+7 (923) 303-0152
krsk@dia-m.ru

Казань
+7 (843) 210-2080
kazan@dia-m.ru

Ростов-на-Дону
+7 (863) 303-5500
rnd@dia-m.ru

Екатеринбург
+7 (912) 658-7606
ekb@dia-m.ru

Кемерово
+7 (923) 158-6753
kemerovo@dia-m.ru

Армения
+7 (094) 01-0173
armenia@dia-m.ru

